

# STI StopperSwitches®

## Waterproof Push Buttons



### STANDARD MODELS:

#### **Access Control Buttons:**

WSS3-7G14 - White Housing, Green Button, Momentary, DPC  
WSS3-3W14 - Green Housing, White Button, Momentary, DPC

#### **Emergency Power Off Buttons:**

WSS3-5R04 - Yellow Housing, Red Button, Key to Reset, DPC  
WSS3-5Y04 - Yellow Housing, Yellow Button, Key to Reset, DPC

#### **Emergency/Evacuate Buttons:**

WSS3-7B04 - White Housing, Blue Button, Key to Reset, DPC  
WSS3-9W04 - Blue Housing, White Button, Key to Reset, DPC

#### **Panic/Isolate Buttons:**

WSS3-1W04 - Red Housing, White Button, Key to Reset, DPC  
WSS3-7R04 - White Housing, Red Button, Key to Reset, DPC

### BUILD YOUR OWN MODELS:

For all available models please refer to BUILD YOUR OWN MODEL on reverse. Any non-standard models will require longer lead times. For further information on any of the StopperSwitch models, please contact Sales on +44 (0)1527 520 999.

## PRODUCT OVERVIEW

A highly versatile range of attractive waterproof Push Buttons combining unique design, quality and value. These aesthetically appealing, low/high voltage switches are quick and easy to install.

- **StopperPush** – Models are for applications where momentary push and release activation is desired.
- **StopperLatch** – Models are for applications where repeat activation must be controlled. Once the switch has been manually activated, it can only be reset by inserting a special key.

All models are available in a variety of colours with space for function marking and operating instructions. A number of standard models are available for quick delivery but enquiries for custom models are welcomed.

It is advisable to protect your StopperSwitches with an STI Universal Stopper®. The protective cover consists of a tough polycarbonate material and is available with or without integral sounder. The cover adds an extra measure of protection against damage from the elements and accidental activations. The Universal Stopper is ideal for StopperSwitches installed in outdoor areas, or areas prone to getting wet such as swimming pools and wash down areas. For further protection from ingress, see Enviro Stopper®.

## KEY FEATURES

### **General Information**

- Highly versatile range of attractive Waterproof Push Buttons combining unique design, quality and value.
- One year guarantee on electromechanical and electronic components.

### **Design**

- Inset design on the push button helps prevent accidental activation.

### **Construction**

- Extremely attractive, high value look and feel: space available for function marking and operating instructions.

### **Installation**

- Operating temperature -20°C (-4°F) to 65°C (149°F).

### **Electronics**

- Wide range of operating voltages up to 250 volts AC 6 Amps: Rated 3A, (12-24 VDC) & 6A, (125 250 VAC).

### **Options**

- Other models available - KeySwitches and Indoor Push Button.
- Low profile, heavy-duty terminations - available in SPC & DPC arrangements.
- It is advised to protect the Push Button with an STI Protective Cover.



For more information, call +44 (0)1527 520 999 or visit [www.sti-emea.com](http://www.sti-emea.com)



**Safety Technology  
International**

# STI StopperSwitches - Waterproof Push Buttons

Dimensions and Technical Information

## BUILD YOUR OWN MODEL

**Prefix Options:**  
WSS3 = Waterproof StopperSwitch

**Housing Colour & Mounting Options:**  
1 = Red with Back Box (Surface Mount only)  
3 = Green with Back Box (Surface Mount only)  
5 = Yellow with Back Box (Surface Mount only)  
7 = White with Back Box (Surface Mount only)  
9 = Blue with Back Box (Surface Mount only)  
E = Orange with Back Box (Surface Mount only)

**Button Colour:**  
R = Red  
G = Green  
Y = Yellow  
W = White  
B = Blue  
E = Orange  
*NB: Please see Button Colour Conditionals below.*

**Button Type Options:**  
0 = Latching (Key-to-Reset)  
1 = Momentary

**Electrical Arrangement Options:**  
4 = Multi-Function Signal (SPC & DPC)

**Label Options:**  
For 'Standard Function Marking Kit' no additional coding is required. Affix required text upon installation. Standard Function Marking Labels (black or white: depending on colour housing selected) include:  
- EMERGENCY - ISOLATE  
- EMERGENCY POWER OFF - PANIC ALARM  
- EMERGENCY STOP - POOL ALARM  
- EVACUATE - PRESS TO EXIT  
- EXIT - SHUT DOWN  
- GAS SHUT OFF - SMOKE VENT

For Custom Label, add **-CL** to Product Code.  
Maximum 20 characters including spacing (1 line)



Push Button Models: Technical Specifications	
Current Carrying Capacity (non switching)	3A 12-24V DC / 6A 125-250V AC
Electrical Contact Material	Silver plated brass
Housing & Back Box Material	Polycarbonate
Terminal Conductor Size	0.5mm - 2.5mm
Operating Temperature	-20°C to 65°C (-4°F to 149°F)
Mounting	Surface

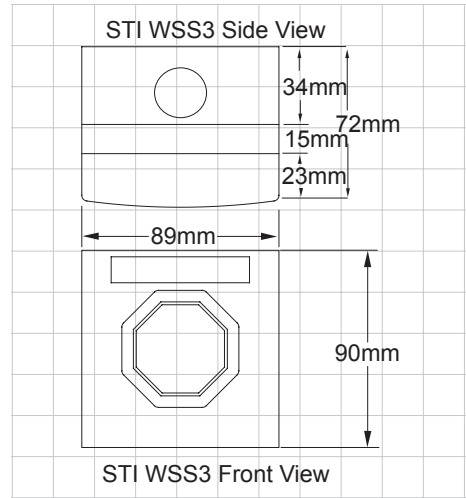

### Button Colour Conditionals: Button colour and available Housing colours

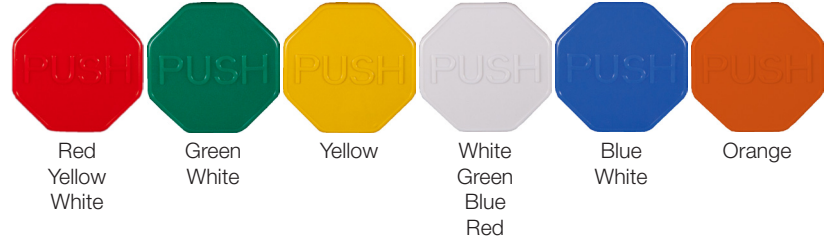

### Electrical Arrangement Options:

**4 Multi-Function Signal:**  
Available for Key-to-Reset and Momentary Models only. Can achieve Single Pole Changeover and Double Pole Changeover.

**Cover Options:**  
**PLEASE NOTE:** Covers are ordered separately. Other covers are available.

**Integral Cover**  
Designed to fit directly to the cover of the button, preventing accidental activation.

**Call Point Stopper**  
Designed to retrofit over MCP's and buttons, preventing accidental activation.

**Euro Stopper**  
Designed to retrofit over MCP's and buttons, preventing both accidental or malicious activation, available with or without an integral alarm.

**Universal Stopper**  
Indoor and outdoor dome covers designed to retrofit over MCP's and emergency push buttons. Available with or without an integral sounder.



**Safety Technology International**

**UK Office**  
Taylor House  
34 Sherwood Road  
Bromsgrove  
Worcestershire  
B60 3DR, England

Tel: +44 (0)1527 520 999  
Fax: +44 (0)1527 501 999  
info@sti-emea.com  
www.sti-emea.com

**USA Head Office**  
2306 Airport Road  
Waterford, Michigan  
48327 - 1209

Tel: +248-673-9898  
Fax: +248-673-1246  
Toll-free: 0800-888-4STI  
info@sti-usa.com  
www.sti-usa.com