

STI STOPPER® STATION SHIELD



STI-6517

PRODUCT OVERVIEW

This inexpensive and highly durable cover was invented to mount directly onto the Stopper® Station series of buttons. With two tabs that snap into the Stopper Station, the cover easily mounts over the push button. It takes hard knocks in stride while protecting the button against vandalism, damage or accidental activation.

BACKED BY A THREE YEAR GUARANTEE

As all STI protective covers, this Stopper Station Shield is backed by a three year guarantee against breakage in normal use. It is also highly cost effective and easy to install.

KEY FEATURES

General Information

- Protects against vandalism, damage and accidental activation.
- Raised molded "LIFT HERE."
- Three year guarantee against breakage of polycarbonate in normal use (one year on electro mechanical and electronic components).

Design

- Cover specifically designed to fit STI Stopper Stations with notched mounting slots (see reverse).

Construction

- Cover is molded from thick, tough polycarbonate material.
- Cover is UV-stabilized.

Installation

- Ideal for use when space is limited.
- Tabs snap into Stopper Station shell allowing for fast and easy installation.
- Polycarbonate rated -40° to 120°F (-40° to 49°C).

Electronics

- STI-6517A has a selectable 65 or 85 dB alert when lifted.
- STI-6517B is wireless and has a selectable 65 or 85 dB alert when lifted.
- STI-6517C sends wireless signal when cover is lifted or button is pressed.
- STI-6517D sounds a 65 or 85 dB alert and sends wireless signal when button is pressed.

Options

- Available with alert or alert and wireless.
- Standard French and Spanish label available.

STI Stopper® Station Shield

Dimensions and Technical Information

MODELS AVAILABLE

STI-6517	Stopper Station Shield
STI-6517A	Stopper Station Shield with sound
STI-6517B*	Wireless Stopper Station Shield with sound
STI-6517C*	Stopper Station Shield with Wireless Transmitter
STI-6517D*	Stopper Station Shield with Button Sound and Transmitter
STI-6517-FR	Shield with "LEVEZ ICI"
STI-6517-ES	Shield with "LEVANTE AQUI"

ACCESSORIES

KIT-E02111PCB	Stopper Station Shield Piezo Sounder
STI-34066-B	Stopper Station Horn and Transmitter
STI-34066-C	Stopper Station Transmitter
STI-34066-D	Stopper Station Horn and Transmitter

NOTE: Special order. Please contact STI sales for ordering information.

*Requires STI-V34104 4-Channel Voice Receiver or STI-34108 8-Channel Receiver.

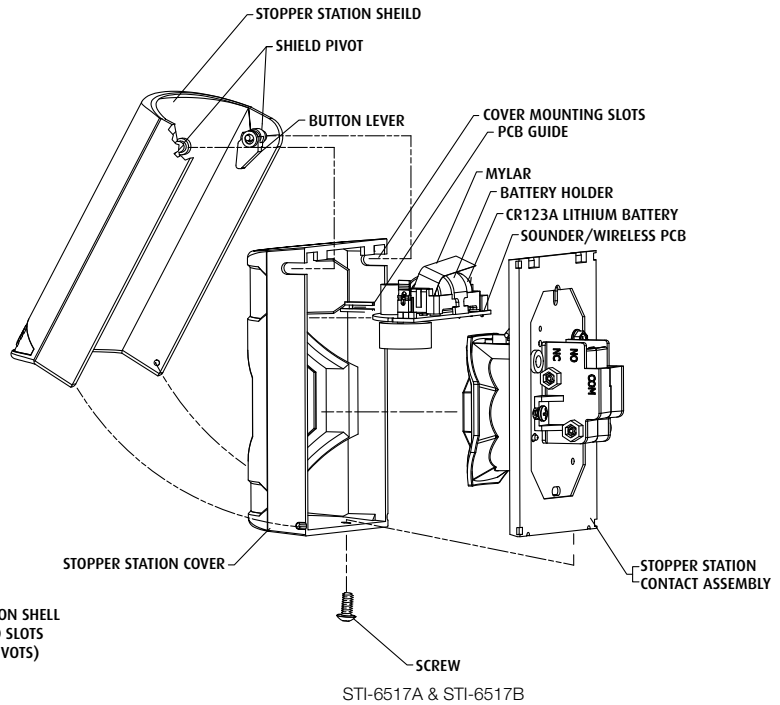
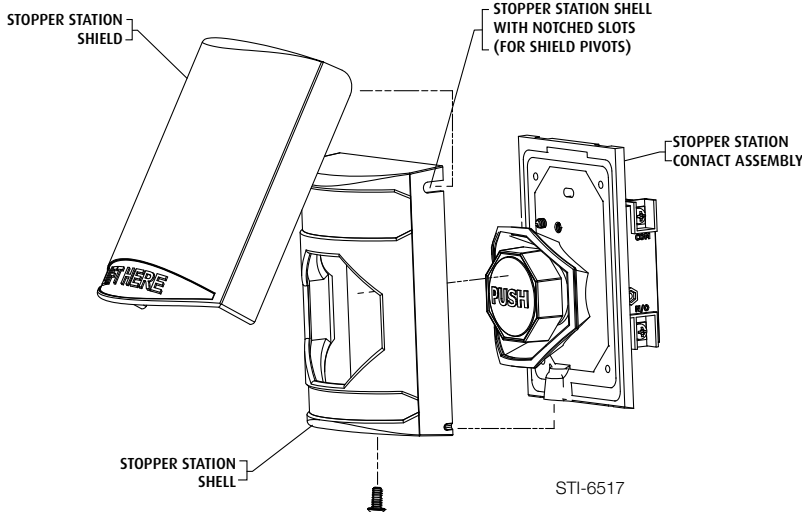
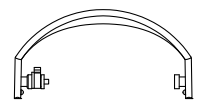
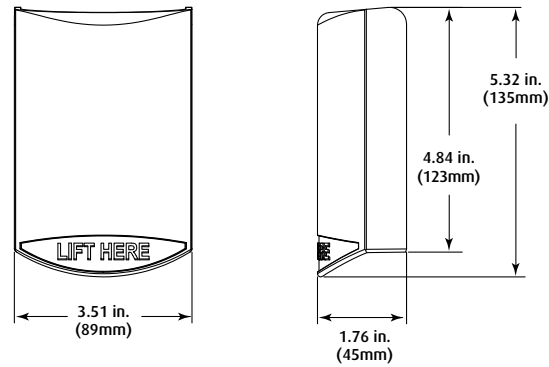

APPROVALS & WARRANTY

TESTING

- UL and cUL S7255
- ADA Compliant

STI-6517B

- FCC & IC Compliant

WARRANTY

Three year guarantee against breakage of polycarbonate in normal use.



Safety Technology International

2306 Airport Road
Waterford, Michigan
48327, USA

Tel: 248-673-9898
Fax: 248-673-1246
info@sti-usa.com
www.sti-usa.com

Taylor House
34 Sherwood Road
Bromsgrove, Worcestershire
B60 3DR, England

Tel: +44 (0)1527 520 999
Fax: +44 (0)1527 501 999
info@sti-emea.com
www.sti-emea.com